

LC PLASMA TORCHES, CONSUMABLES & ACCESSORIES



LINCOLN[®]
ELECTRIC

LINCOLN ELECTRIC ITALIA S.r.l
Via Fratelli Canepa 8, 16010 Serrà Riccò (GE), Italia
www.lincolnelectric.eu

Declaration of conformity
Dichiarazione di conformità
Konformitätserklärung
Declaración de conformidad
Déclaration de conformité
Samsvars erklæring



Verklaring van overeenstemming
Försäkran om överensstämmelse
Deklaracja zgodności
Vakuutus yhteensopivuudesta
Declaração de Conformidade
Декларация соответствия

LINCOLN ELECTRIC ITALIA S.r.l.

Declares that the plasma cutting torch:
Dichiara che la torcia taglio plasma tipo:
Erklärt, daß die Plasmaschneidbrenner:
Declara que la antorcha plasma tipo:
Déclare que le torche découpage plasma type:
Angi at plasma skjære pistolen:

Verklaard hierbij dat de Plasmatoorts:
Försäkrar att plasmabrännaren:
Deklaruje że uchwył do cięcia plazmą:
Ilmoittaa, että plasmaleikkauspoltin:
Declara que a tocha de corte plasma:
Декларирует, что плазменная горелка:

LC25
LC40, LC40M
LC60, LC60M
LC80, LC80M
LC100, LC100M

conforms to the following directives:
è conforme alle seguenti direttive:
den folgenden Bestimmungen entspricht:
es conforme con las siguientes directivas:
est conforme aux directives suivantes:
er i samsvar med følgende direktiver:

overeenkomt conform de volgende richtlijnen:
överensstämmer med följande direktiv:
spełnia następujące wytyczne:
täyttää seuraavat direktiivit:
está em conformidade com as seguintes directivas:
соответствует следующим директивам:

2006/95/CEE

and has been designed in compliance with the following standards:
ed è stato progettato in conformità alle seguenti norme:
und in Übereinstimmung mit den nachstehenden normen hergestellt wurde:
y ha sido diseñado de acuerdo con las siguientes normas:
et qu'il a été conçu en conformité avec les normes:
og er produsert og testet iht. følgende standarder:

en is ontworpen conform de volgende normen:
och att den konstruerats i överensstämmelse med följande standarder:
i że zostało zaprojektowane zgodnie z wymaganiami następujących norm:
ja on suunniteltu seuraavien standardien mukaan:
e foi concebida com as seguintes normas:
и разработана с использованием стандартам:

EN 60974-7

(18.09.2008)

Dario Gatti
European Engineering Director Machines
LINCOLN ELECTRIC ITALIA S.r.l., Via Fratelli Canepa 8, 16010 Serra Riccò (GE), Italia

Declaration of conformity
Dichiarazione di conformità
Konformitätserklärung
Declaración de conformidad
Déclaration de conformité
Samsvars erklæring



Verklaring van overeenstemming
Försäkran om överensstämmelse
Deklaracja zgodności
Vakuutus yhteensopivuudesta
Declaração de Conformidade
Декларация соответствия

LINCOLN ELECTRIC ITALIA S.r.l.

Declares that the plasma cutting torch:
Dichiara che la torcia taglio plasma tipo:
Erklärt, daß die Plasmaschneidbrenner:
Declara que la antorcha plasma tipo:
Déclare que le torche découpage plasma type:
Angi at plasma skjære pistolen:

Verklaard hierbij dat de Plasmatoorts:
Försäkrar att plasmabrännaren:
Deklaruje że uchwyt do cięcia plazmą:
Ilmoittaa, että plasmaleikkauspoltin:
Declara que a tocha de corte plasma:
Декларирует, что плазменная горелка:

LC65, LC65M LC105, LC105M

conforms to the following directives:
è conforme alle seguenti direttive:
den folgenden Bestimmungen entspricht:
es conforme con las siguientes directivas:
est conforme aux directives suivantes:
er i samsvar med følgende direktiver:

overeenkomt conform de volgende richtlijnen:
överensstämmer med följande direktiv:
spełnia następujące wytyczne:
täyttää seuraavat direktiivit:
está em conformidade com as seguintes directivas:
соответствует следующим директивам:

2006/95/CEE

and has been designed in compliance with the following standards:
ed è stato progettato in conformità alle seguenti norme:
und in Übereinstimmung mit den nachstehenden normen hergestellt wurde:
y ha sido diseñado de acuerdo con las siguientes normas:
et qu'il a été conçu en conformité avec les normes:
og er produsert og testet iht. følgende standarder:

en is ontworpen conform de volgende normen:
och att den konstruerats i överensstämmelse med följande standarder:
i że zostało zaprojektowane zgodnie z wymaganiami następujących norm:
ja on suunniteltu seuraavien standardien mukaan:
e foi concebida com as seguintes normas:
и разработана с использованием стандартам:

EN 60974-7

(24.06.2009)





Dario Gatti
European Engineering Director Machines
LINCOLN ELECTRIC ITALIA S.r.l., Via Fratelli Canepa 8, 16010 Serra Riccò (GE), Italia

English		<p>Do not dispose of electrical equipment together with normal waste! In observance of European Directive 2002/96/EC on Waste Electrical and Electronic Equipment (WEEE) and its implementation in accordance with national law, electrical equipment that has reached the end of its life must be collected separately and returned to an environmentally compatible recycling facility. As the owner of the equipment, you should get information on approved collection systems from our local representative. By applying this European Directive you will protect the environment and human health!</p>
Italiano		<p>Non gettare le apparecchiature elettriche tra i rifiuti domestici! In ottemperanza alla Direttiva Europea 2002/96/CE sui Rifiuti di Apparecchiature Elettriche ed Elettroniche (RAEE) e la sua attuazione in conformità alle norme nazionali, le apparecchiature elettriche esauste devono essere raccolte separatamente e restituite ad una organizzazione di riciclaggio eco-compatibile. Come proprietario dell'apparecchiatura, Lei potrà ricevere informazioni circa il sistema approvato di raccolta, dal nostro rappresentante locale. Applicando questa Direttiva Europea Lei contribuirà a migliorare l'ambiente e la salute!</p>
Deutsch		<p>Werfen Sie Elektrowerkzeuge nicht in den Hausmüll! Gemäss Europäischer Richtlinie 2002/96/EG über Elektro- und Elektronik- Altgeräte (Waste Electrical and Electronic Equipment, WEEE) und Umsetzung in nationales Recht müssen verbrauchte Elektrowerkzeuge getrennt gesammelt und einer umweltgerechten Wiederverwertung zugeführt werden. Als Eigentümer dieser Werkzeuge sollten sie sich Informationen über ein lokales autorisiertes Sammel- bzw. Entsorgungssystem einholen. Mit der Anwendung dieser EU Direktive tragen sie wesentlich zur Schonung der Umwelt und ihrer Gesundheit bei!</p>
Español		<p>No tirar nunca los aparatos eléctricos junto con los residuos en general. De conformidad a la Directiva Europea 2002/96/EC relativa a los Residuos de Equipos Eléctricos o Electrónicos (RAEE) y al acuerdo de la legislación nacional, los equipos eléctricos deberán ser recogidos y reciclados respetando el medioambiente. Como propietario del equipo, deberá informar de los sistemas y lugares apropiados para la recogida de los mismos. Aplicar esta Directiva Europea protegerá el medioambiente y su salud!</p>
Français		<p>Ne pas jeter les appareils électriques avec les déchets ordinaires! Conformément à la Directive Européenne 2002/96/EC relative aux Déchets d'Équipements Électriques ou Électroniques (DEEE), et à sa transposition dans la législation nationale, les appareils électriques doivent être collectés à part et être soumis à un recyclage respectueux de l'environnement. En tant que propriétaire de l'équipement, vous devriez vous informer sur les systèmes de collecte approuvés auprès nos représentants locaux. Appliquer cette Directive Européenne améliorera l'environnement et la santé!</p>
Norsk		<p>Kast ikke elektriske artikler sammen med vanlig søppel. I følge det europeiske direktivet for Elektronisk Søppel og Elektriske Artikler 2002/96/EC (Waste Electrical and Electronic Equipment, WEEE) skal alt avfall kildesorteres og leveres på godkjente plasser i følge loven. Godkjente retur plasser gis av lokale myndigheter. Ved å følge det europeiske direktivet bidrar du til å bevare naturen og den menneskelige helse.</p>
Nederlandse		<p>Gooi elektrische apparatuur nooit bij gewoon afval! Met inachtneming van de Europese Richtlijn 2002/96/EC met betrekking tot Afval van Elektrische en Elektronische Apparatuur (Waste Electrical and Electronic Equipment, WEEE) en de uitvoering daarvan in overeenstemming met nationaal recht, moet elektrische apparatuur, waarvan de levensduur ten einde loopt, apart worden verzameld en worden ingeleverd bij een recycling bedrijf, dat overeenkomstig de milieuwetgeving opereert. Als eigenaar van de apparatuur moet u informatie inwinnen over goedgekeurde verzamelingsystemen van onze vertegenwoordiger ter plaatse. Door het toepassen van deze Europese Richtlijn beschermt u het milieu en ieders gezondheid!</p>
Svenska		<p>Släng inte utjänt elektrisk utrustning tillsammans med annat avfall! Enligt Europadirektiv 2002/96/EC ang. Utjänt Elektrisk och Elektronisk Utrustning (Waste Electrical and Electronic Equipment, WEEE) och dess implementering enligt nationella lagar, ska elektrisk utrustning som tjänat ut sorteras separat och lämnas till en miljögodkänd återvinningsstation. Som ägare till utrustningen, bör du skaffa information om godkända återvinningssystem från dina lokala myndigheter. Genom att följa detta Europadirektiv bidrar du till att skydda miljön och hälsa!</p>
Polski		<p>Nie wyrzucać sprzętu elektrycznego razem z normalnymi odpadami! Zgodnie z Dyrektywą Europejską 2002/96/EC dotyczącą Pozbywania się zużytego Sprzętu Elektrycznego i Elektronicznego (Waste Electrical and Electronic Equipment, WEEE) i jej wprowadzeniem w życie zgodnie z międzynarodowym prawem, zużyty sprzęt elektryczny musi być składowany oddzielnie i specjalnie utylizowany. Jako właściciel urządzeń powinniście otrzymać informacje o zatwierdzonym systemie składowania od naszego lokalnego przedstawiciela. Stosując te wytyczne bedziesz chronił środowisko i zdrowie człowieka!</p>
Suomi		<p>Älä hävittää sähkölaitteita sekajätteiden mukana! Noudatettaessa Euroopan Unionin Direktiiviä 2002/96/EY Sähkölaite- ja Elektroniikkajätteestä (WEEE) ja toteutettaessa sitä sopuisoinnussa kansallisen lain kanssa, sähkölaite, joka on tullut elinkaarensa päähän pitää kerätä erilleen ja toimittaa sähkö- ja elektroniikkaromujen keräyspisteeseen. Lisätietoja tämän tuotteen käsittelystä, keräämisestä ja kierrätyksestä saa kunnan ympäristöviranomaisilta. Noudattamalla tätä Euroopan Unionin direktiiviä, autat torjumaan kielteiset ympäristö- ja terveysvaikutukset!</p>
Português		<p>Não deitar fora o equipamento eléctrico juntamente com o lixo normal! Em conformidade com a directiva Europeia 2002/96/EC relativa a Resíduos Eléctricos e Equipamento Eléctricos (REEE) e de acordo com a legislação nacional, os equipamentos deverão ser recolhidos separadamente e reciclados respeitando o meio ambiente. Como proprietário do equipamento, deverá informar-se dos sistemas e lugares apropriados para a recolha dos mesmos. Ao aplicar esta Directiva Europeia protegerá o meio ambiente e a saúde humana!</p>
Русский		<p>Запрещается утилизация электротехнических изделий вместе с обычным мусором! В соблюдение Европейской Директивы 2002/96/EC в отношении использованного электротехнического оборудования "Waste Electrical and Electronic Equipment" (WEEE) и исполнение в соответствии с региональным законодательством, электротехническое оборудование, достигшее окончания срока эксплуатации должно быть собрано на специальные площадки и утилизировано отдельно на соответствующих участках (заводах) по утилизации. Вы, как владелец оборудования, должны получить информацию об сертифицированных площадках для сбора оборудования от нашего локального представительства. Соблюдая Европейскую Директиву по утилизации отработавшего электротехнического оборудования, вы защищаете здоровье людей и окружающую среду от загрязнения!</p>

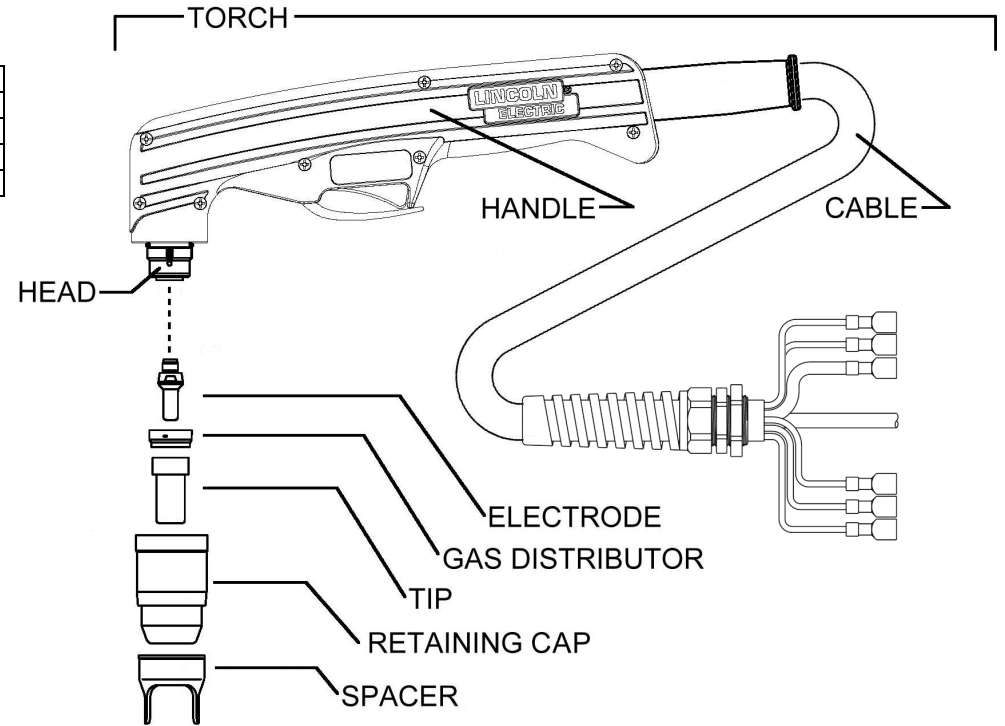
LC25

LC25		
Torch (Hand 3m)	(1pc)	PTH-C25A-SL-3MR
Handle	(1pc)	W0300601R
Head	(1pc)	W0300615R
Cable (3m)	(1pc)	W0300616R



	Electrode (blister 5pcs)	Gas Distr. (blister 3pcs)	Tip (blister 5pcs)	Retaining Cap (blister 1pc)	Spacer (blister 1pcs)
Cutting process					
25A	W03X0893 -75A	W03X0893 -5R	W03X0893 -76A	W03X0893 -77A	W03X0893 -78R

LC40 & LC60

		LC40	LC60
Torch (Hand 6m)	(1pc)	PTH-040A-CX-6MA	
Torch (Hand 7.5m)	(1pc)		PTH-060A-CX-7M5A
Torch (Hand 15m)	(1pc)	PTH-040A-CX-15MA	PTH-060A-CX-15MA
Handle	(1pc)	W0300601R	
Head	(1pc)	W0300600R	
Cooling Kit	(blister 1pc)	W03X0893-4R	
Cable (7.5m)	(1pc)	W0300604R	
Cable (15m)	(1pc)	W0300606R	
Connector	(1pc)	W03X0934-2R	W03X0934-4R

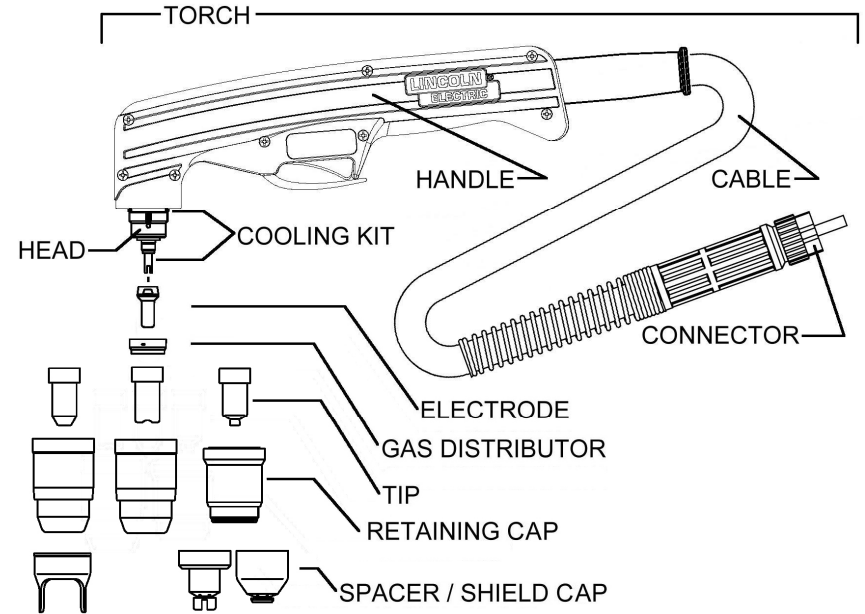

	Electrode (blister 5pcs)		Gas Distr. (blister 3pcs)	Tip (blister 5pcs)				Retaining Cap (blister 1pc)		Spacer (blister 2pcs)		Shield Cap (blister 2pcs)	
Cutting process													
40A	W03X0893-1A		W03X0893-5R	W03X0893-2A				W03X0893-10A		W03X0893-14R			
50A	W03X0893-1A		W03X0893-5R	W03X0893-3A				W03X0893-10A		W03X0893-14R			
60A	W03X0893-1A		W03X0893-5R	W03X0893-15A				W03X0893-10A		W03X0893-14R			
Dir Contact 25A	W03X0893-1A		W03X0893-5R		W03X0893-18A			W03X0893-10A					
Dir Contact 40A	W03X0893-1A		W03X0893-5R		W03X0893-8A			W03X0893-10A					
Contact 50A	W03X0893-1A		W03X0893-5R		W03X0893-6A		W03X0893-11A		W03X0893-11A			W03X0893-7A	
Contact 60A	W03X0893-1A		W03X0893-5R		W03X0893-17A		W03X0893-11A		W03X0893-11A			W03X0893-7A	
Ext Contact 40A		W03X0893-19A				W03X0893-20A							W03X0893-21A
Gouging	W03X0893-1A		W03X0893-5R		W03X0893-9A		W03X0893-11A						W03X0893-13A

LC40M & LC60M – LC40M GEAR RACK & LC60M GEAR RACK

		LC40M	LC40M GEAR RACK	LC60M	LC60M GEAR RACK
Torch (Machine 6m)	(1pc)	PTM-040A-CX-6MA			
Torch (Machine 7.5m)	(1pc)	PTM-060A-CX-7M5A			
Torch (Machine 15m)	(1pc)	PTM-040A-CX-15MA		PTM-060A-CX-15MA	
Positioning tube	(1pc)	W0300603R	W0300624R	W0300603R	W0300624R
Head	(1pc)	W0300602R			
Cooling Kit	(blister 1pc)	W03X0893-4R			
Cable (7.5m)	(1pc)	W0300605R			
Cable (15m)	(1pc)	W0300607R			
Connector	(1pc)	W03X0934-2R		W03X0934-4R	

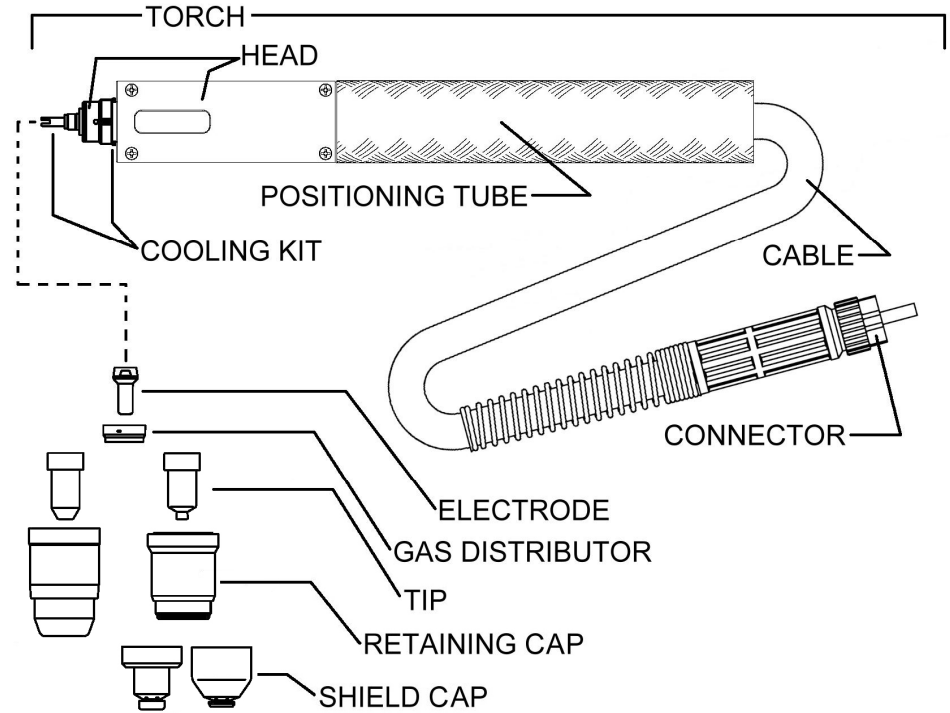

	Electrode (blister 5pcs)	Gas Distr. (blister 3pcs)	Tip (blister 5pcs)		Retaining Cap (blister 1pc)		Shield Cap (blister 2pcs)	
Cutting process								
40A	W03X0893 -1A	W03X0893 -5R	W03X0893 -2A		W03X0893 -10A			
50A	W03X0893 -1A	W03X0893 -5R	W03X0893 -3A		W03X0893 -10A			
60A	W03X0893 -1A	W03X0893 -5R	W03X0893 -15A		W03X0893 -10A			
Shielded 40A	W03X0893 -1A	W03X0893 -5R		W03X0893 -16A	W03X0893 -11A		W03X0893 -12A	
Shielded 50A	W03X0893 -1A	W03X0893 -5R		W03X0893 -6A	W03X0893 -11A		W03X0893 -12A	
Shielded 60A	W03X0893 -1A	W03X0893 -5R		W03X0893 -17A	W03X0893 -11A		W03X0893 -12A	
Gouging	W03X0893 -1A	W03X0893 -5R		W03X0893 -9A	W03X0893 -11A			W03X0893 -13A

LC65

LC65		
Torch (Hand 7.5m)	(1pc)	PTH-061A-CX-7M5A
Torch (Hand 15m)	(1pc)	PTH-061A-CX-15MA
Handle	(1pc)	W0300609R
Head	(1pc)	W0300608R
Cooling Kit	(blister 1pc)	W03X0893-49R
Cable (7.5m)	(1pc)	W0300604R
Cable (15m)	(1pc)	W0300606R
Connector	(1pc)	W03X0934-4R

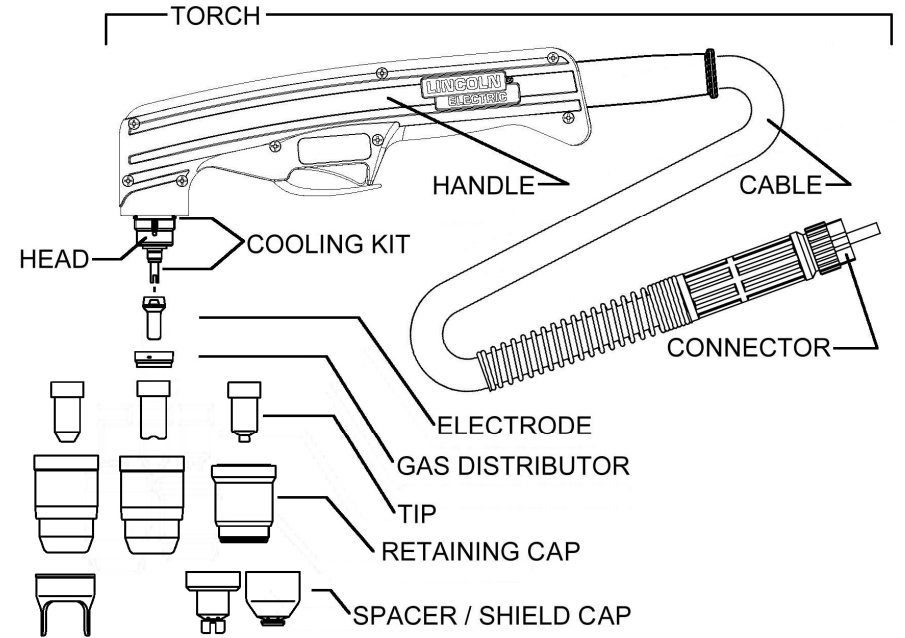

	Electrode (blister 5pcs)		Gas Distr. (blister 3pcs)	Tip (blister 5pcs)				Retaining Cap (blister 1pc)	Spacer (blister 2pcs)	Shield Cap (blister 2pcs)			
Cutting process													
40A	W03X0893-25A		W03X0893-50R	W03X0893-27A				W03X0893-41A		W03X0893-14R			
50A	W03X0893-25A		W03X0893-50R	W03X0893-28A				W03X0893-41A		W03X0893-14R			
60A	W03X0893-25A		W03X0893-50R	W03X0893-29A				W03X0893-41A		W03X0893-14R			
Dir Contact 40A	W03X0893-25A		W03X0893-50R		W03X0893-26A			W03X0893-41A					
Contact 50A	W03X0893-25A		W03X0893-50R			W03X0893-33A			W03X0893-43A			W03X0893-44A	
Contact 60A	W03X0893-25A		W03X0893-50R			W03X0893-34A			W03X0893-43A			W03X0893-44A	
Ext Contact 40A		W03X0893-53A										W03X0893-21A	
Ext Contact 60A		W03X0893-53A										W03X0893-21A	
Gouging	W03X0893-25A		W03X0893-50R			W03X0893-39A			W03X0893-43A				W03X0893-48A

LC65M – LC65M GEAR RACK

	LC65M	LC65M GEAR RACK
Torch (Machine 7.5m) (1pc)		PTM-061A-CX-7M5A
Torch (Machine 15m) (1pc)		PTM-061A-CX-15MA
Positioning tube (1pc)	W0300603R	W0300624R
Head (1pc)		W0300610R
Cooling Kit (blister 1pc)		W03X0893-49R
Cable (7.5m) (1pc)		W0300605R
Cable (15m) (1pc)		W0300607R
Connector (1pc)		W03X0934-4R

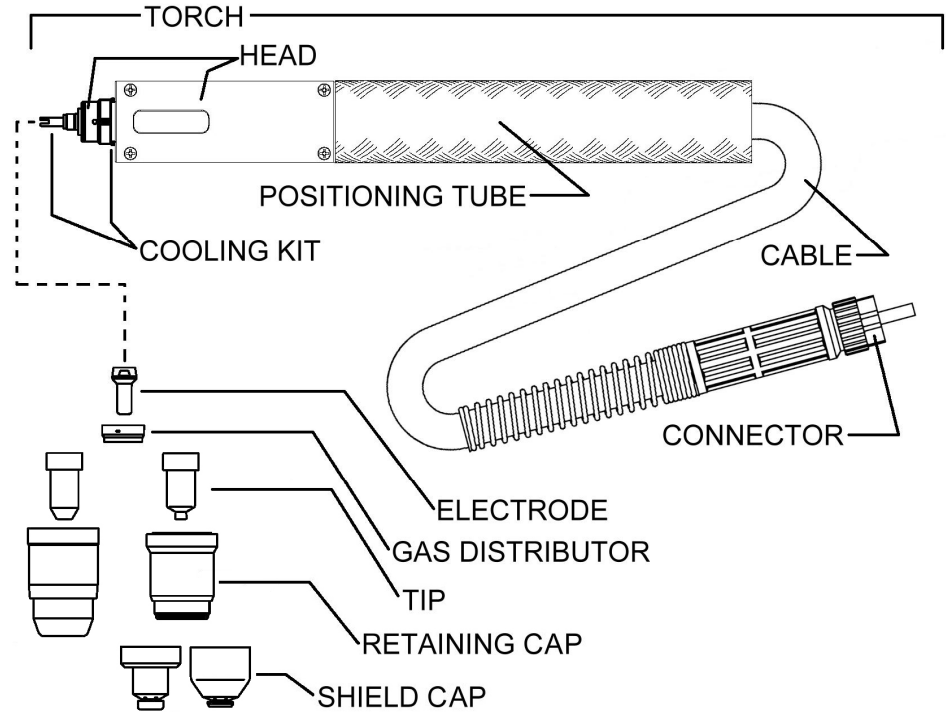







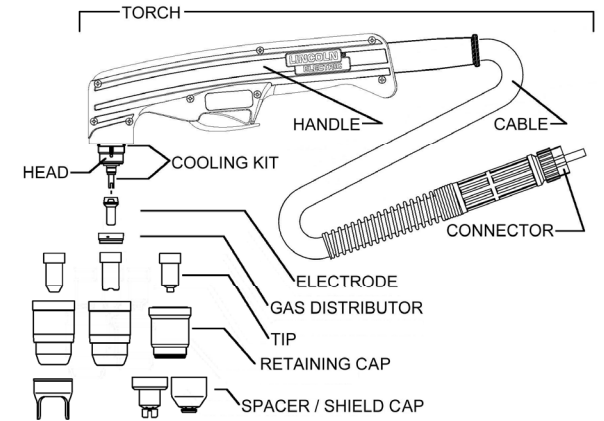

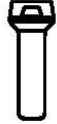
	Electrode (blister 5pcs)	Gas Distr. (blister 3pcs)	Tip (blister 5pcs)		Retaining Cap (blister 1pc)		Shield Cap (blister 2pcs)	
Cutting process								
40A	W03X0893 -25A	W03X0893 -50R	W03X0893 -27A		W03X0893 -41A			
50A	W03X0893 -25A	W03X0893 -50R	W03X0893 -28A		W03X0893 -41A			
60A	W03X0893 -25A	W03X0893 -50R	W03X0893 -29A		W03X0893 -41A			
Shielded 40A	W03X0893 -25A	W03X0893 -50R		W03X0893 -52A		W03X0893 -43A	W03X0893 -46A	
Shielded 50A	W03X0893 -25A	W03X0893 -50R		W03X0893 -33A		W03X0893 -43A	W03X0893 -46A	
Shielded 60A	W03X0893 -25A	W03X0893 -50R		W03X0893 -34A		W03X0893 -43A	W03X0893 -46A	
Gouging	W03X0893 -25A	W03X0893- 50R		W03X0893 -39A		W03X0893 -43A		W03X0893 -48A

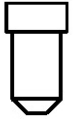
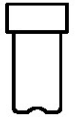
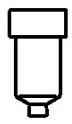
LC80 & LC100

		LC80	LC100
Torch (Hand 7.5m)	(1pc)	PTH-080A-CX-7M5A	PTH-100A-CX-7M5A
Torch (Hand 15m)	(1pc)	PTH-080A-CX-15MA	PTH-100A-CX-15MA
Handle	(1pc)	W0300609R	
Head	(1pc)	W0300608R	
Cooling Kit	(blister 1pc)	W03X0893-49R	
Cable (7.5m)	(1pc)	W0300611R	
Cable (15m)	(1pc)	W0300613R	
Connector	(1pc)	W03X0934-7R	W03X0934-8R

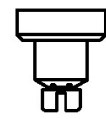
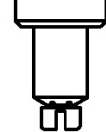







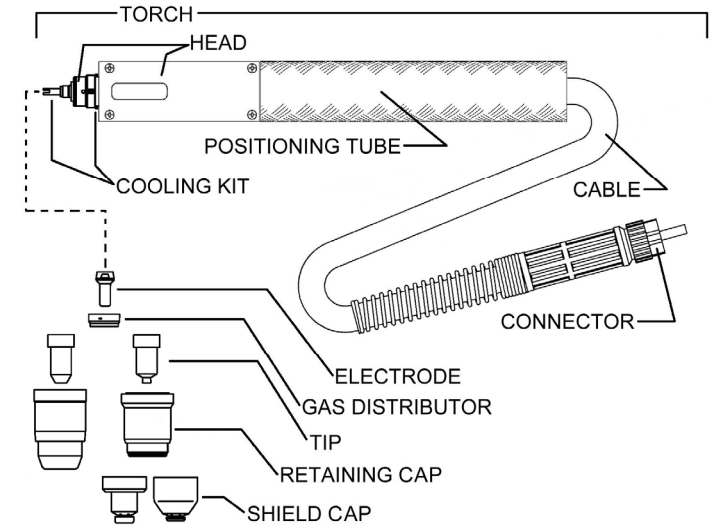

Cutting process	Electrode (blister 5pcs)		Gas Distr. (blister 3pcs)	Tip (blister 5pcs)				Retaining Cap (blister 1pc)		Spacer (blister 2pcs)		Shield Cap (blister 2pcs)	
													
40A	W03X0893-25A		W03X0893-50R	W03X0893-27A				W03X0893-41A		W03X0893-14R			
50A	W03X0893-25A		W03X0893-50R	W03X0893-28A				W03X0893-41A		W03X0893-14R			
60A	W03X0893-25A		W03X0893-50R	W03X0893-29A				W03X0893-41A		W03X0893-14R			
70A	W03X0893-25A		W03X0893-51R	W03X0893-30A				W03X0893-42A		W03X0893-14R			
80A	W03X0893-25A		W03X0893-51R	W03X0893-31A				W03X0893-42A		W03X0893-14R			
100A	W03X0893-25A		W03X0893-51R	W03X0893-32A				W03X0893-42A		W03X0893-14R			
Dir Contact 40A	W03X0893-25A		W03X0893-50R		W03X0893-26A			W03X0893-41A					
Contact 50A	W03X0893-25A		W03X0893-50R			W03X0893-33A		W03X0893-43A			W03X0893-44A		
Contact 60A	W03X0893-25A		W03X0893-50R			W03X0893-34A		W03X0893-43A			W03X0893-44A		
Contact 70A	W03X0893-25A		W03X0893-51R			W03X0893-35A		W03X0893-43A			W03X0893-45A		
Contact 80A	W03X0893-25A		W03X0893-51R			W03X0893-36A		W03X0893-43A			W03X0893-45A		
Contact 100A	W03X0893-25A		W03X0893-51R			W03X0893-37A		W03X0893-43A			W03X0893-45A		
Ext Contact 40A		W03X0893-53A				W03X0893-40A						W03X0893-21A	
Ext Contact 60A		W03X0893-53A				W03X0893-54A						W03X0893-21A	
Gouging	W03X0893-25A		W03X0893-51R			W03X0893-38A		W03X0893-43A					W03X0893-48A

LC80M & LC100M – LC80M GEAR RACK & LC100 M GEAR RACK

		LC80M	LC80M GEAR RACK	LC100M	LC80M GEAR RACK
Torch (Machine 7.5m)	(1pc)	PTM-080A-CX-7M5A		PTM-100A-CX-7M5A	
Torch (Machine 15m)	(1pc)	PTM-080A-CX-15MA		PTM-100A-CX-15MA	
Positioning tube	(1pc)	W0300603R	W0300624R	W0300603R	W0300624R
Head	(1pc)	W0300610R			
Cooling Kit	(blister 1pc)	W03X0893-49R			
Cable (7.5m)	(1pc)	W0300612R			
Cable (15m)	(1pc)	W0300614R			
Connector	(1pc)	W03X0934-7R		W03X0934-8R	



Cutting process	Electrode (blister 5pcs)	Gas Distr. (blister 3pcs)	Tip (blister 5pcs)		Retaining Cap (blister 1pc)		Shield Cap (blister 2pcs)	
								
40A	W03X0893 -25A	W03X0893 -50R	W03X0893 -27A		W03X0893 -41A			
50A	W03X0893 -25A	W03X0893 -50R	W03X0893 -28A		W03X0893 -41A			
60A	W03X0893 -25A	W03X0893 -50R	W03X0893 -29A		W03X0893- 41A			
70A	W03X0893 -25A	W03X0893 -51R	W03X0893 -30A		W03X0893 -42A			
80A	W03X0893 -25A	W03X0893 -51R	W03X0893 -31A		W03X0893 -42A			
100A	W03X0893 -25A	W03X0893 -51R	W03X0893 -32A		W03X0893 -42A			
Shielded 40A	W03X0893 -25A	W03X0893 -50R		W03X0893 -52A		W03X0893 -43A	W03X0893 -46A	
Shielded 50A	W03X0893 -25A	W03X0893 -50R		W03X0893 -33A		W03X0893 -43A	W03X0893 -46A	
Shielded 60A	W03X0893 -25A	W03X0893 -50R		W03X0893 -34A		W03X0893 -43A	W03X0893 -46A	
Shielded 70A	W03X0893 -25A	W03X0893 -51R		W03X0893 -35A		W03X0893 -43A	W03X0893 -47A	
Shielded 80A	W03X0893 -25A	W03X0893 -51R		W03X0893 -36A		W03X0893 -43A	W03X0893 -47A	
Shielded 100A	W03X0893 -25A	W03X0893 -51R		W03X0893 -37A		W03X0893 -43A	W03X0893 -47A	
Gouging	W03X0893 -25A	W03X0893 -51R		W03X0893 -38A		W03X0893 -43A		W03X0893 -48A

LC105

LC105		
Torch (Hand 7.5m)	(1pc)	PTH-101A-CX-7M5A
Torch (Hand 15m)	(1pc)	PTH-101A-CX-15MA
Handle	(1pc)	W0300609R
Head	(1pc)	W0300618R
Insulation Kit	(blister 1pc)	W03X0893-71R
Cable (7.5m)	(1pc)	W0300620R
Cable (15m)	(1pc)	W0300622R
Connector	(1pc)	W03X0934-8R

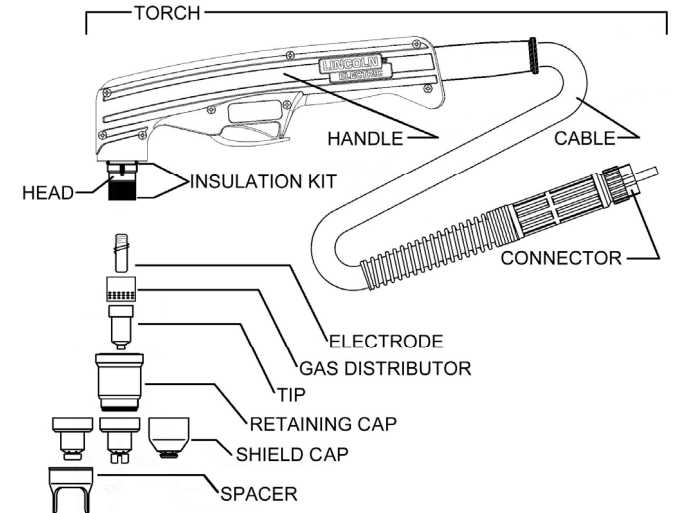



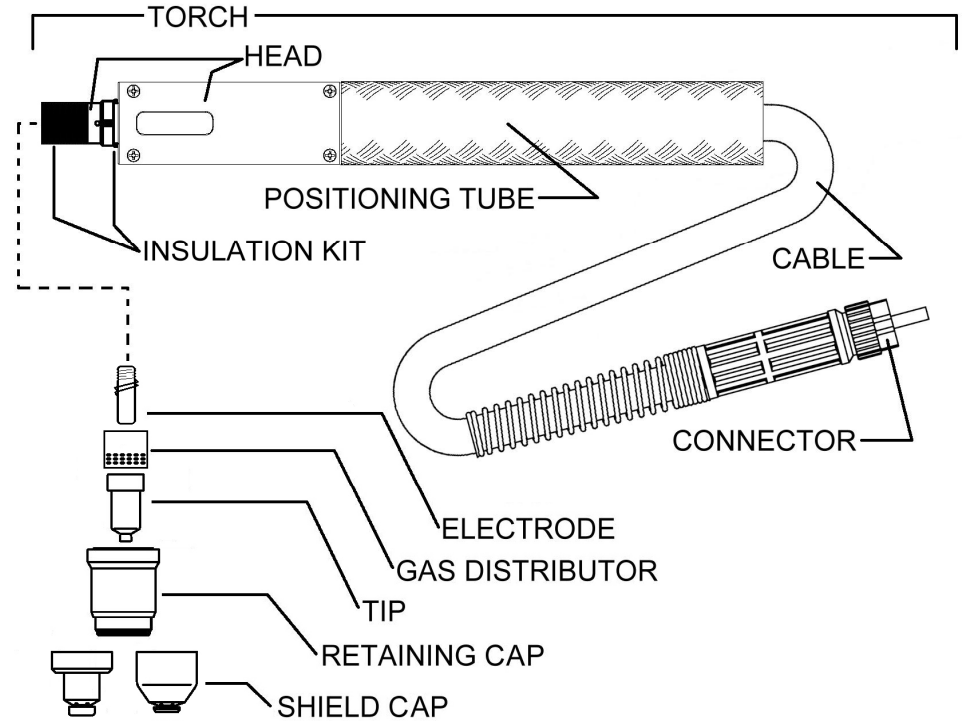

	Electrode (blister 5pcs)		Gas Distr. (blister 2pcs)	Tip (blister 5pcs)		Retaining Cap (blister 1pc)	Spacer (blister 2pcs)	Shield Cap (blister 2pcs)			
Cutting process											
40A	W03X0893 -60A		W03X0893 -70R	W03X0893 -61A		W03X0893 -66A	W03X0893 -14R	W03X0893 -68A			
60A	W03X0893 -60A		W03X0893 -70R	W03X0893 -62A		W03X0893 -66A	W03X0893 -14R	W03X0893 -68A			
80A	W03X0893 -60A		W03X0893 -70R	W03X0893 -63A		W03X0893 -66A	W03X0893 -14R	W03X0893 -68A			
100A	W03X0893 -60A		W03X0893 -70R	W03X0893 -64A		W03X0893 -66A	W03X0893 -14R	W03X0893 -68A			
Contact 40A	W03X0893 -60A		W03X0893 -70R	W03X0893 -61A		W03X0893 -66A			W03X0893 -67A		
Contact 60A	W03X0893 -60A		W03X0893 -70R	W03X0893 -62A		W03X0893 -66A			W03X0893 -67A		
Contact 80A	W03X089 3-60A		W03X0893 -70R	W03X0893 -63A		W03X0893 -66A			W03X0893 -67A		
Contact 100A	W03X089 3-60A		W03X0893 -70R	W03X0893 -64A		W03X0893 -66A			W03X0893 -67A		
Ext Contact 40A		W03X0893 -57A									W03X0893 -74A
Ext Contact 60A		W03X0893 -57A									W03X0893 -74A
Ext Contact 80A		W03X0893 -57A									W03X0893 -74A
Ext Contact 100A		W03X0893 -57A									W03X0893 -74A
Gouging	W03X0893 -60A		W03X0893 -70R	W03X0893 -65A		W03X0893 -66A					W03X0893 -69A

LC105M – LC105M GEAR RACK

	LC105M	LC105M GEAR RACK
Torch (Machine 7.5m) (1pc)		PTM-101A-CX-7M5A
Torch (Machine 15m) (1pc)		PTM-101A-CX-15MA
Positioning tube (1pc)	W0300603R	W0300624R
Head (1pc)		W0300619R
Insulation Kit (blister 1pc)		W03X0893-71R
Cable (7.5m) (1pc)		W0300621R
Cable (15m) (1pc)		W0300623R
Connector (1pc)		W03X0934-8R



	Electrode (blister 5pcs)	Gas Distr. (blister 2pcs)	Tip (blister 5pcs)	Retaining Cap (blister 1pc)	Shield Cap (blister 2pcs)
Cutting process					
40A	W03X0893 -60A	W03X0893 -70R	W03X0893 -61A	W03X0893 -66A	W03X0893 -68A
60A	W03X0893 -60A	W03X0893 -70R	W03X0893 -62A	W03X0893 -66A	W03X0893 -68A
80A	W03X0893 -60A	W03X0893 -70R	W03X0893 -63A	W03X0893 -66A	W03X0893 -68A
100A	W03X0893 -60A	W03X0893 -70R	W03X0893 -64A	W03X0893 -66A	W03X0893 -68A
Gouging	W03X0893 -60A	W03X0893 -70R	W03X0893 -65A	W03X0893 -66A	W03X0893 -69A

LC25 - LC40 - LC60 - LC65 - LC80 - LC100 - LC105

LC Circle Kit (optional)

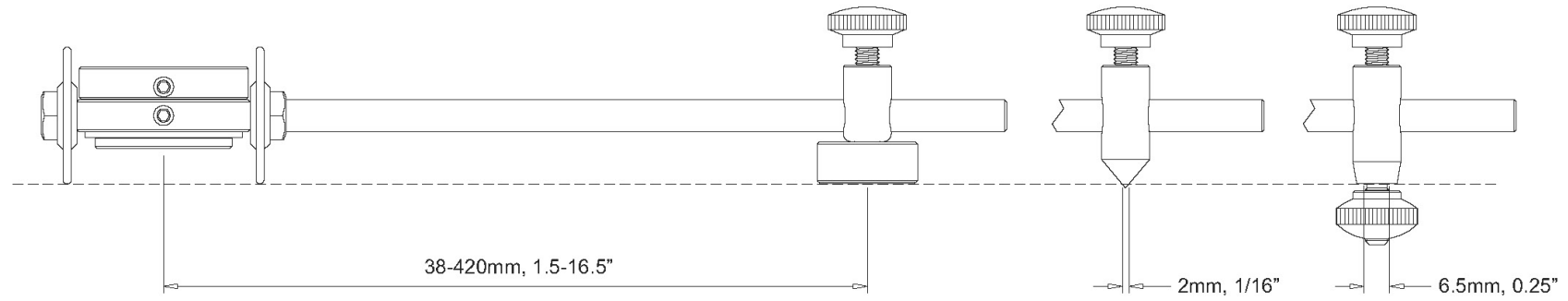

W0300699A LC Circle Kit (optional)

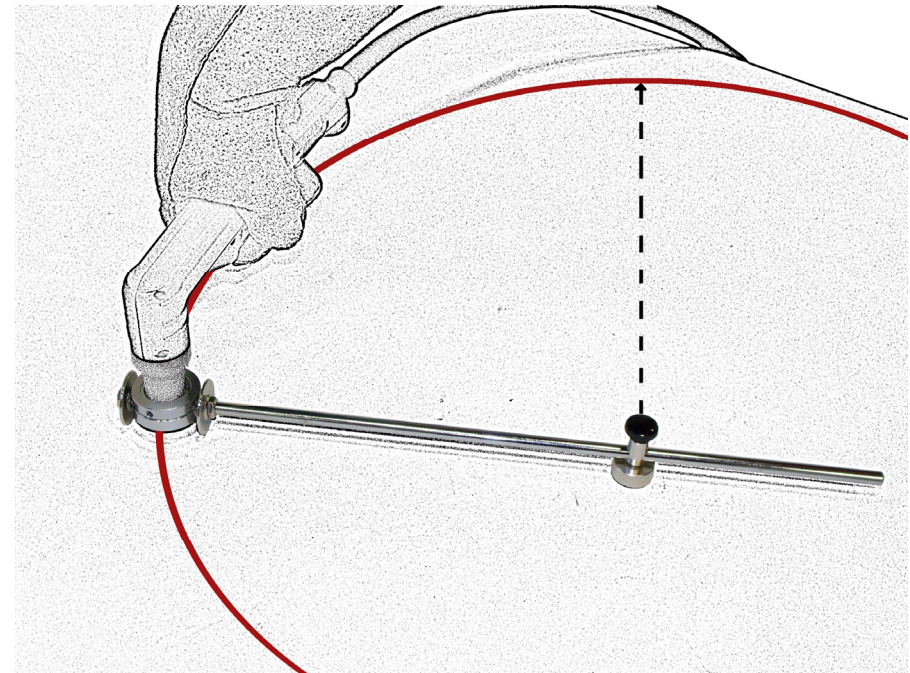

Torches Dimensions

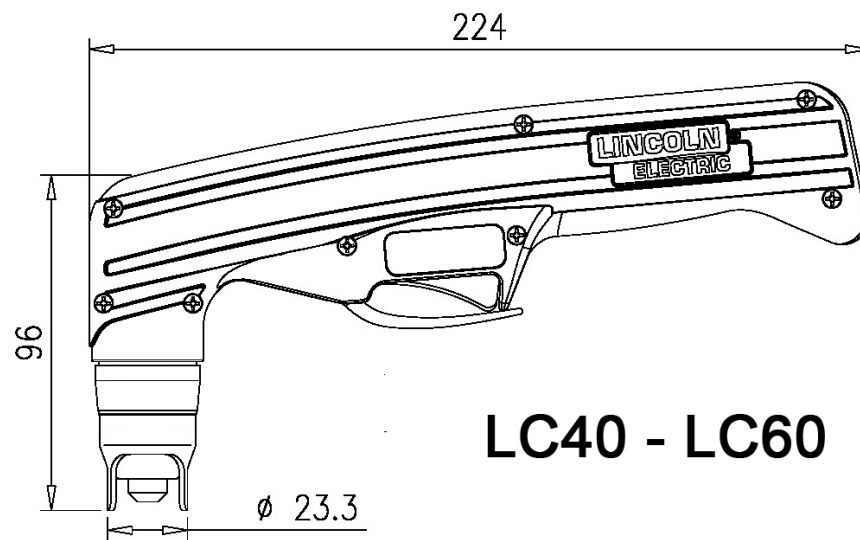
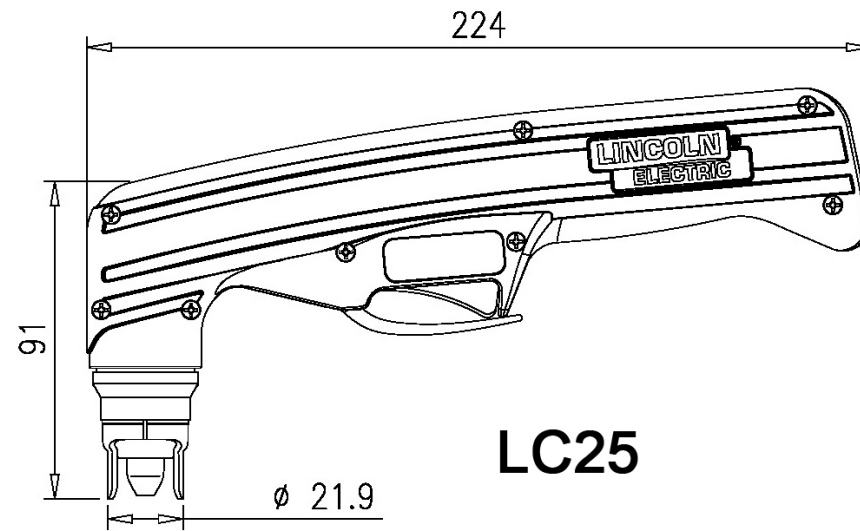

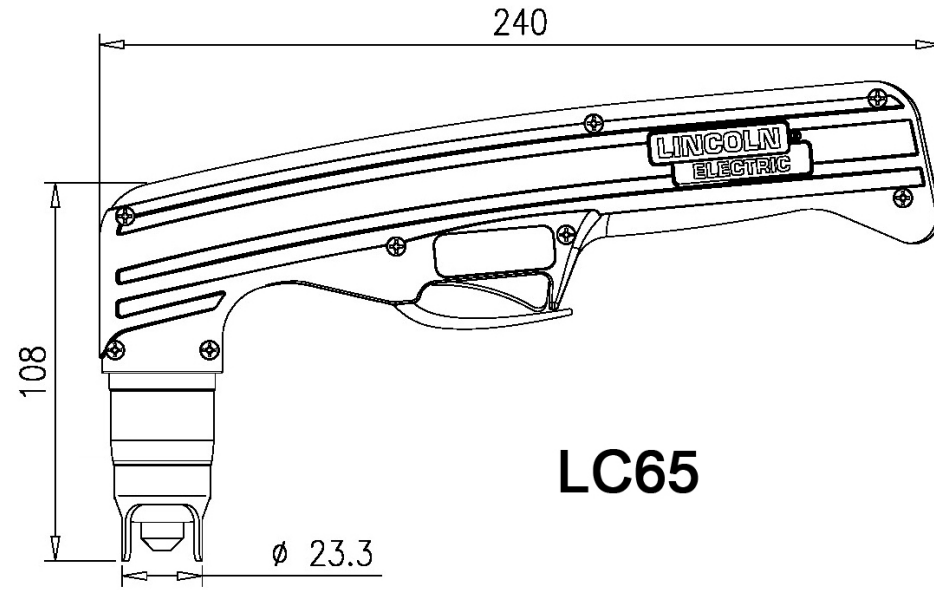

LC65

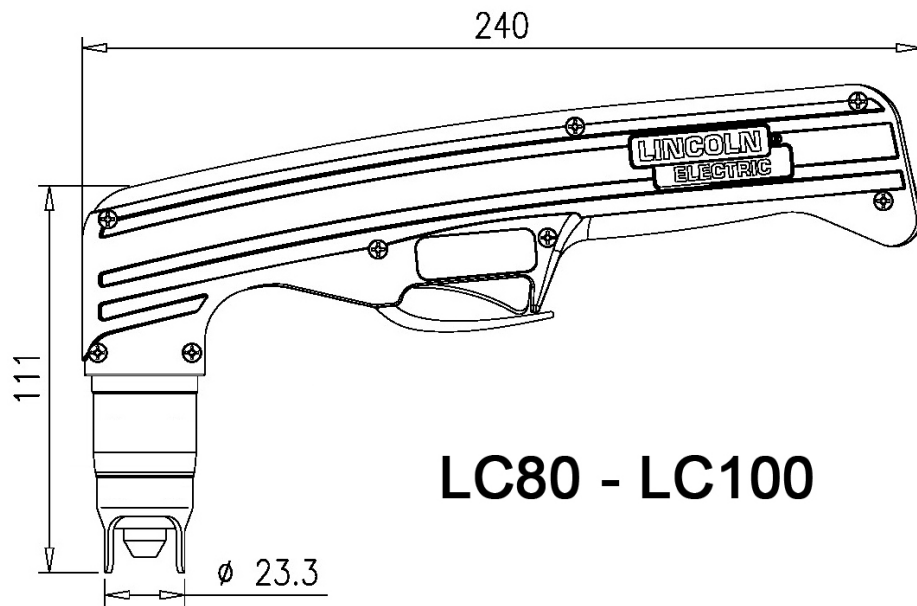

LC80 - LC100

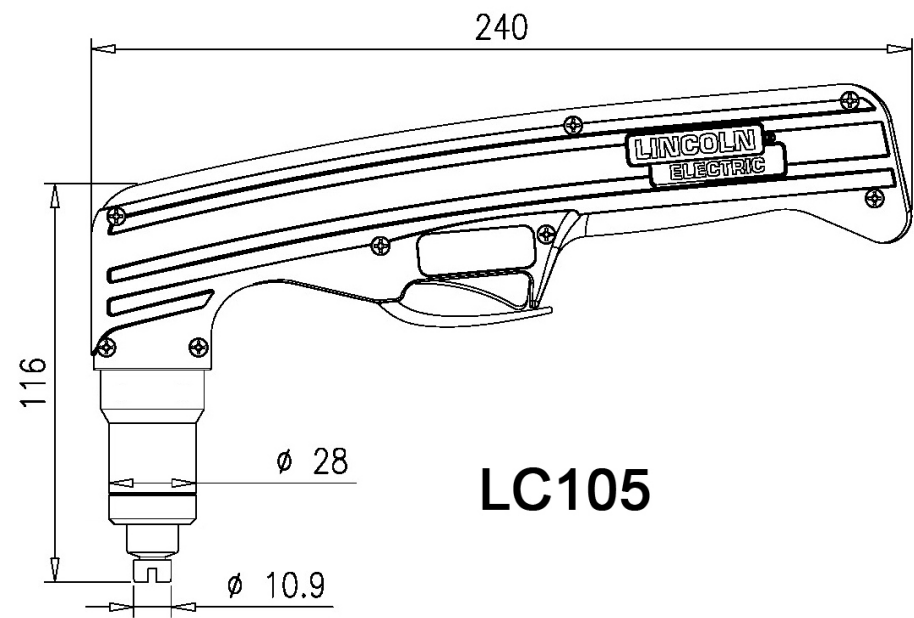

LC105

