

Current Transducer LT 505-S

$$I_{PN} = 500 \text{ A}$$

For the electronic measurement of currents : DC, AC, pulsed..., with a galvanic isolation between the primary circuit (high power) and the secondary circuit (electronic circuit).



0623

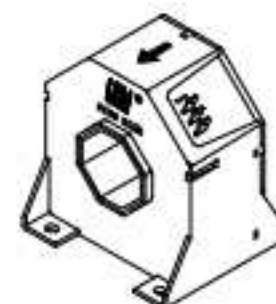

Electrical data

I_{PN}	Primary nominal r.m.s. current	500	A					
I_P	Primary current, measuring range	0 .. ± 1200	A					
R_M	Measuring resistance @	$T_A = 70^\circ\text{C}$		$T_A = 85^\circ\text{C}$				
		R_{Mmin}	R_{Mmax}	R_{Mmin}	R_{Mmax}			
		with $\pm 15 \text{ V}$	@ $\pm 500 \text{ A}_{max}$	0	65	0	60	Ω
			@ $\pm 800 \text{ A}_{max}$	0	15	0	12	Ω
	with $\pm 24 \text{ V}$	@ $\pm 500 \text{ A}_{max}$	0	145	15	140	Ω	
		@ $\pm 1200 \text{ A}_{max}$	0	22	15	18	Ω	
I_{SN}	Secondary nominal r.m.s. current	100	mA					
K_N	Conversion ratio	1 : 5000						
V_C	Supply voltage ($\pm 5\%$)	$\pm 15 \dots 24$	V					
I_C	Current consumption	30 (@ $\pm 24 \text{ V}$) + I_S	mA					
V_d	R.m.s. voltage for AC isolation test, 50 Hz, 1 mn	6	kV					
V_b	R.m.s. rated voltage ¹⁾ , safe separation	1750	V					
		basic isolation	3500	V				

Accuracy - Dynamic performance data

X_G	Overall accuracy @ I_{PN} , $T_A = 25^\circ\text{C}$	± 0.6	%
ϵ_L	Linearity error	< 0.1	%
I_O	Offset current @ $I_P = 0$, $T_A = 25^\circ\text{C}$	Typ	± 0.4 mA
		Max	± 0.5 mA
I_{OT}	Thermal drift of I_O	$-10^\circ\text{C} \dots +85^\circ\text{C}$	± 0.3 mA
t_r	Response time ²⁾ @ 90 % of I_{PN}	< 1	μs
di/dt	di/dt accurately followed	> 50	A/ μs
f	Frequency bandwidth (-1 dB)	DC .. 150	kHz

General data

T_A	Ambient operating temperature	-10 .. +85	$^\circ\text{C}$
T_S	Ambient storage temperature	-25 .. +100	$^\circ\text{C}$
R_S	Secondary coil resistance @	$T_A = 70^\circ\text{C}$	65 Ω
		$T_A = 85^\circ\text{C}$	69 Ω
m	Mass	400	g
	Standards	EN 50178: 1997	

Features

- Closed loop (compensated) current transducer using the Hall effect
- Isolated plastic case recognized according to UL 94-V0.

Advantages

- Excellent accuracy
- Very good linearity
- Low temperature drift
- Optimized response time
- Wide frequency bandwidth
- No insertion losses
- High immunity to external interference
- Current overload capability.

Applications

- AC variable speed drives and servo motor drives
- Static converters for DC motor drives
- Battery supplied applications
- Uninterruptible Power Supplies (UPS)
- Switched Mode Power Supplies (SMPS)
- Power supplies for welding applications.

Notes : ¹⁾ Pollution class 2. With a non insulated primary bar which fills the through-hole

²⁾ With a di/dt of 100 A/ μs .

070807/8

LEM reserves the right to carry out modifications on its transducers, in order to improve them, without previous notice.

Dimensions LT 505-S (in mm. 1 mm = 0.0394 inch)

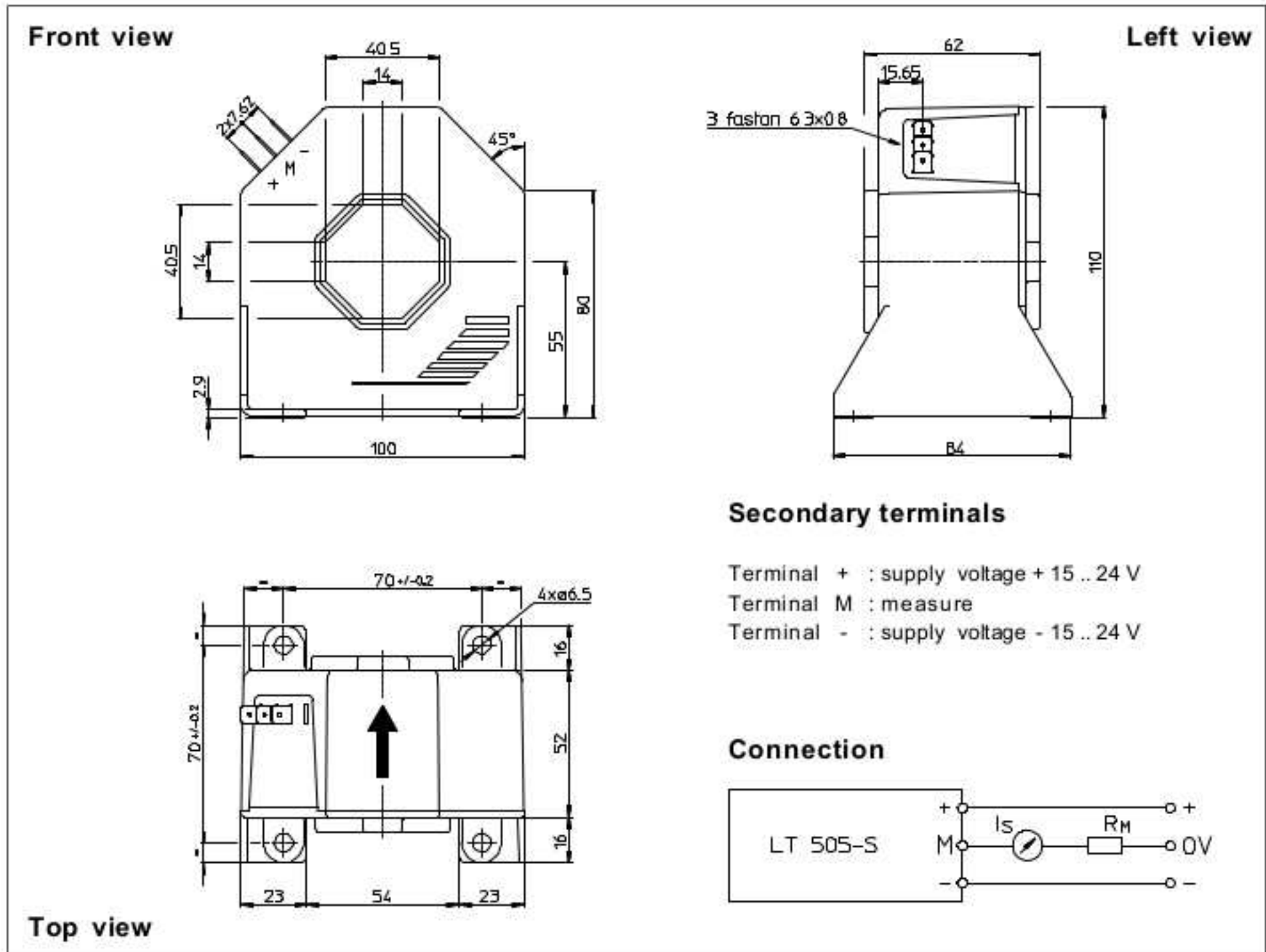

Mechanical characteristics

- General tolerance ± 0.5 mm
- Fastening 4 holes $\varnothing 6.5$ mm
- Primary through-hole 40.5 x 40.5 mm
- Connection of secondary Faston 6.3 x 0.8 mm

Remarks

- I_s is positive when I_p flows in the direction of the arrow.
- Temperature of the primary conductor should not exceed 100°C.
- Dynamic performances (di/dt and response time) are best with a single bar completely filling the primary hole.
- This is a standard model. For different versions (supply voltages, turns ratios, unidirectional measurements...), please contact us.

LEM reserves the right to carry out modifications on its transducers, in order to improve them, without previous notice.



Nasze strony: www.spaw-serwisch.pl • ecm-electronic.pl

Dystrybucja, serwis, sprzedaż - kontakt:

e-mail: spawserwisch@gmail.com, biuro@ecm-electronic.pl

tel. kont.: +48 501 283 621, +48 34 368 1578 (z fax.)

